

FIG. A - PLAN VIEW CUT-OUT

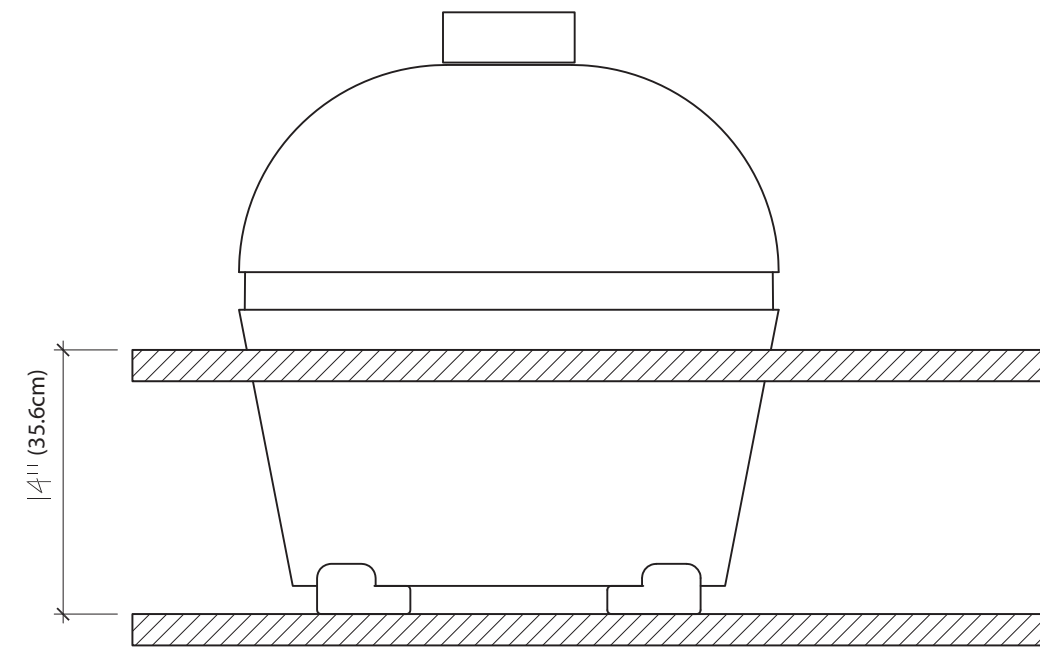

FIG. B - ELEVATION - HT. FROM TOP SURFACE TO SUPPORTING SHELF

TO HAVE THE LIP OF GRILL LOWER TO THE COUNTERTOP SURFACE USE THE TEMPLATE WITH THE HINGE NOTCH

DATE 06.13.2013

REVISIONS

DATE

SCALE SCALE - AS SHOWN

JOB NO. DRAWN BY G.L.W.

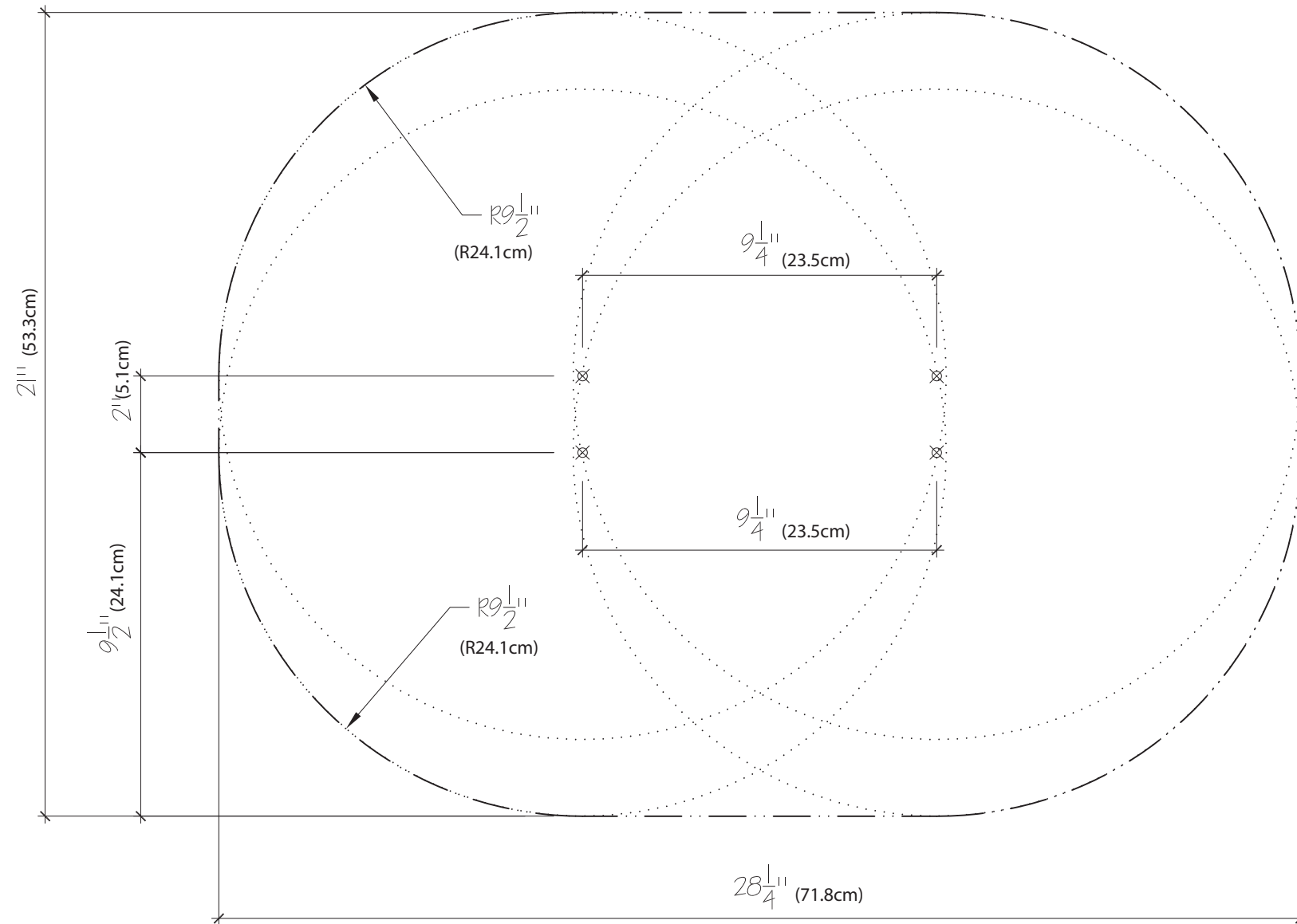

FIG. A - PLAN VIEW CUT-OUT

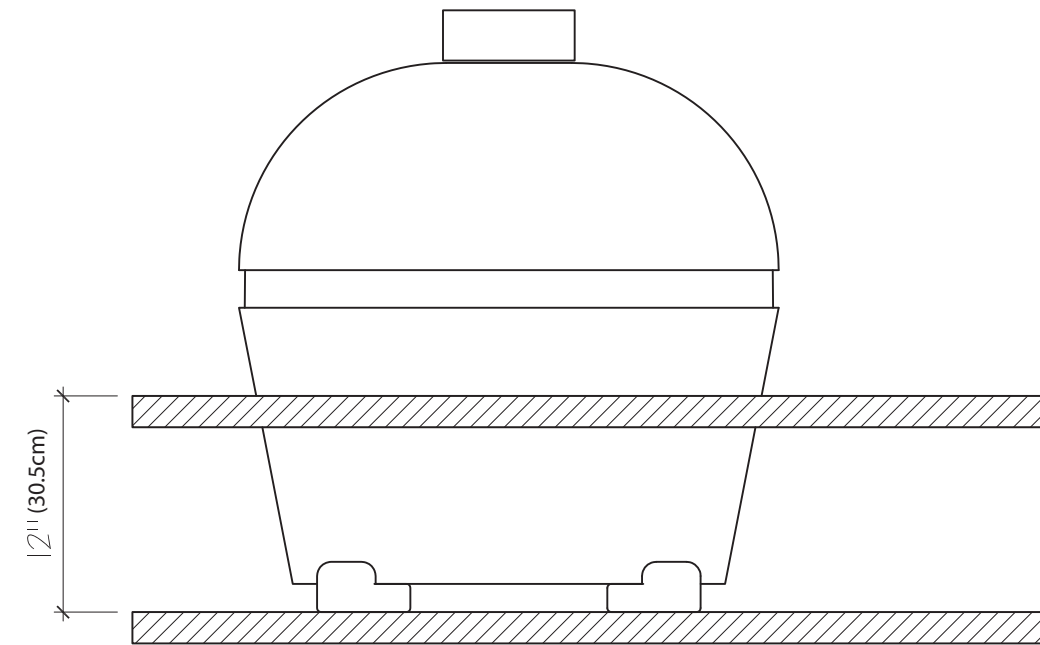

FIG. B - ELEVATION - HT. FROM TOP SURFACE TO SUPPORTING SHELF

DATE	06.13.2013
REVISIONS	
DATE	
SCALE	SCALE - AS SHOWN
JOB NO.	DRAWN BY G.L.W.